



120×120×25 mm

San Ace 120 9GA type Low Power Consumption Fan 

General Specifications

- Material Frame: Plastic (Flammability: UL 94V-0), Impeller: Plastic (Flammability: UL 94V-0)
- Expected life See the table below. (L10 life: 90% survival rate for continuous operation in free air at 60°C, rated voltage)
Expected life at 40°C is for reference only.
- Motor protection function Locked rotor burnout protection, Reverse polarity protection
For details, please refer to p. 573.
- Dielectric strength 50/60 Hz, 500 VAC, for 1 minute (between lead wire conductors and frame)
- Insulation resistance 10 MΩ or more with a 500 VDC megger (between lead wire conductors and frame)
- Sound pressure level (SPL) At 1 m away from the air inlet
- Storage temperature -30 to +70°C (Non-condensing)
- Lead wire ⊕Red ⊖Black (Sensor) Yellow (Control) Brown
(For models without PWM control function, there is no speed control wiring.)
- Mass 280 g

Specifications

The models listed below **have ribs and pulse sensors with PWM control function.** For models without ribs, append "1" to the end of model numbers.

| Model no. | Rated voltage [V] | Operating voltage range [V] | PWM duty cycle [%] | Rated current [A] | Rated input [W] | Rated speed [min ⁻¹] | Max. airflow [m ³ /min] [CFM] | Max. static pressure [Pa] [inchH ₂ O] | SPL [dB (A)] | Operating temperature [°C] | Expected life [h] |
|-----------------|-------------------|-----------------------------|--------------------|-------------------|-----------------|----------------------------------|--|--|--------------|----------------------------|----------------------------|
| » 9GA1212P4G001 | 12 | 10.2 to 13.8 | 100 | 0.93 | 11.16 | 6400 | 3.8 134 | 365 1.47 | 57 | -20 to +70 | 40000/60°C (70000/40°C) |
| » 9GA1212P4S001 | | | 25 | 0.16 | 1.92 | 2550 | 1.5 53 | 60 0.24 | 34 | | |
| » 9GA1224P4G001 | 24 | 20.4 to 27.6 | 100 | 0.47 | 11.28 | 6400 | 3.8 134 | 365 1.47 | 57 | | |
| » 9GA1224P4S001 | | | 25 | 0.1 | 2.4 | 2550 | 1.5 53 | 60 0.24 | 34 | | |
| » 9GA1248P4G001 | 48 | 40.8 to 53 | 100 | 0.24 | 11.52 | 6400 | 3.8 134 | 365 1.47 | 57 | | |
| » 9GA1248P4S001 | | | 25 | 0.08 | 3.84 | 2550 | 1.5 53 | 60 0.24 | 34 | | |

* PWM input frequency is 25 kHz; models without specifications at 0% PWM duty cycle have zero fan speed at 0%.

The following sensor and control options are available for selection.

Available for all models. **Pulse sensor**

Differs according to the model. Refer to the table on p. 605. **Without sensor** **Lock sensor**

The models listed below **have ribs and pulse sensors.** For models without ribs, append "1" to the end of model numbers.

| Model no. | Rated voltage [V] | Operating voltage range [V] | Rated current [A] | Rated input [W] | Rated speed [min ⁻¹] | Max. airflow [m ³ /min] [CFM] | Max. static pressure [Pa] [inchH ₂ O] | SPL [dB (A)] | Operating temperature [°C] | Expected life [h] |
|----------------|-------------------|-----------------------------|-------------------|-----------------|----------------------------------|--|--|--------------|----------------------------|----------------------------|
| » 9GA1212G4001 | 12 | 7 to 13.8 | 0.93 | 11.16 | 6400 | 3.8 134 | 365 1.47 | 57 | -20 to +70 | 40000/60°C (70000/40°C) |
| » 9GA1212S4001 | | | 0.61 | 7.32 | 5400 | 3.2 113 | 260 1.04 | 54 | | |
| » 9GA1224G4001 | 24 | 14 to 27.6 | 0.47 | 11.28 | 6400 | 3.8 134 | 365 1.47 | 57 | | |
| » 9GA1224S4001 | | | 0.31 | 7.44 | 5400 | 3.2 113 | 260 1.04 | 54 | | |
| » 9GA1248G4001 | 48 | 36 to 53 | 0.24 | 11.52 | 6400 | 3.8 134 | 365 1.47 | 57 | | |
| » 9GA1248S4001 | | | 0.16 | 7.68 | 5400 | 3.2 113 | 260 1.04 | 54 | | |

The following sensor and control options are available for selection.

Available for all models. **PWM control**

Differs according to the model. Refer to the table on p. 605. **Without sensor** **Lock sensor**

The » mark indicates Short LeadTime Service applicable models. See p. 626 for details.

Airflow - Static Pressure Characteristics / PWM Duty - Speed Characteristics Example

9GA1212P4G001 With pulse sensor with PWM control function

PWM duty cycle

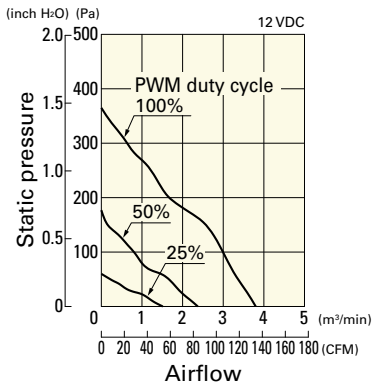

Operating voltage range

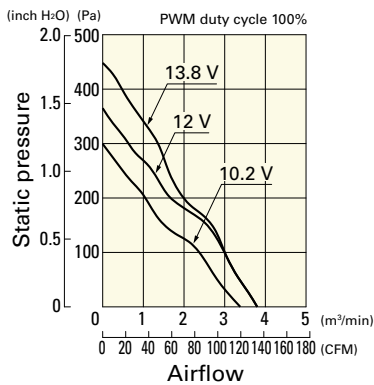

PWM duty - Speed characteristics example

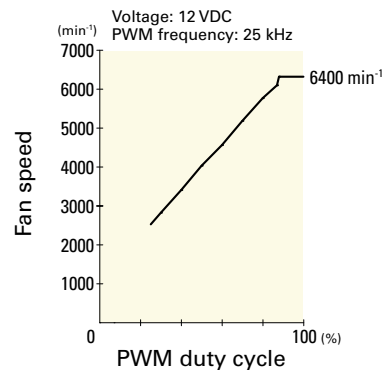

9GA1212P4S001 With pulse sensor with PWM control function

PWM duty cycle

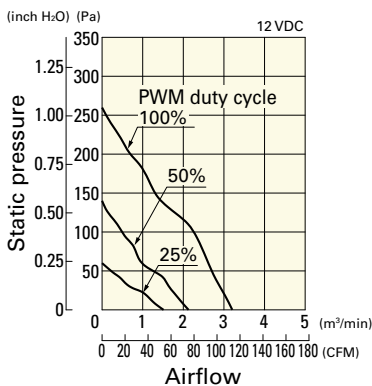

Operating voltage range

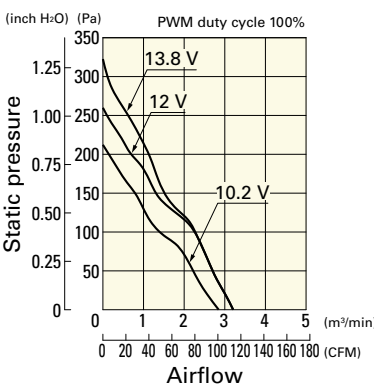

PWM duty - Speed characteristics example

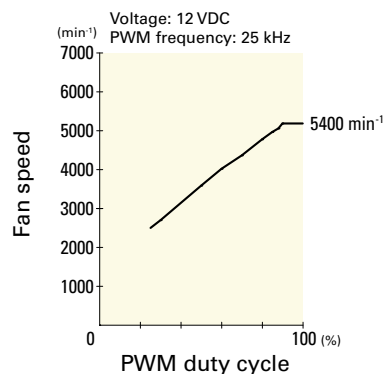

9GA1224P4G001 With pulse sensor with PWM control function

PWM duty cycle

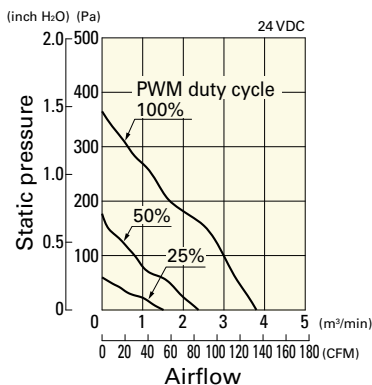

Operating voltage range

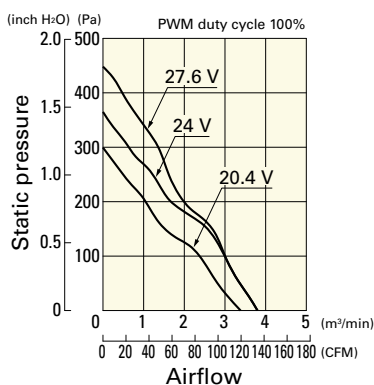

PWM duty - Speed characteristics example

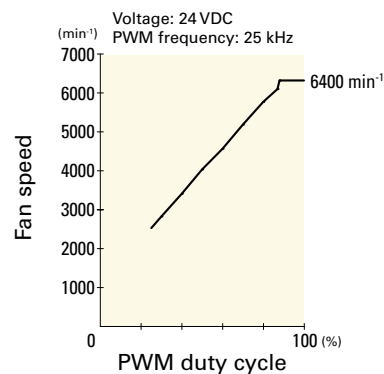

9GA1224P4S001 With pulse sensor with PWM control function

PWM duty cycle

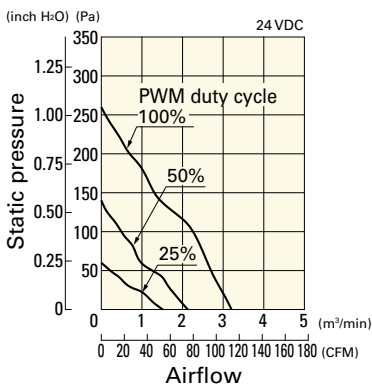

Operating voltage range

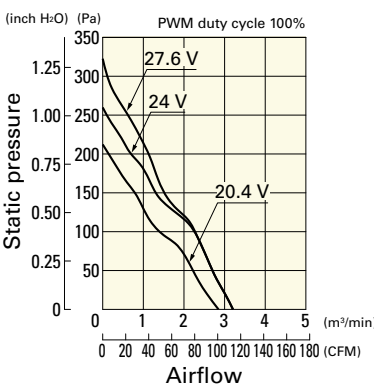

PWM duty - Speed characteristics example

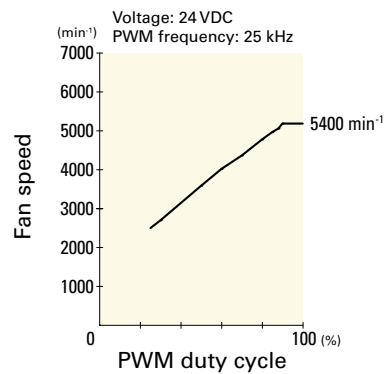

Airflow - Static Pressure Characteristics / PWM Duty - Speed Characteristics Example

9GA1248P4G001 With pulse sensor with PWM control function

PWM duty cycle

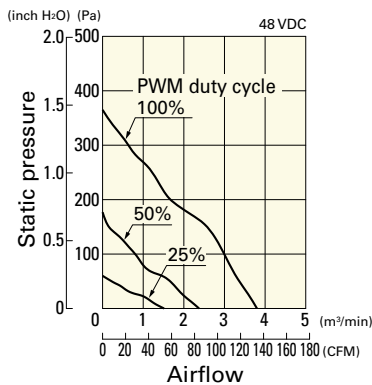

Operating voltage range

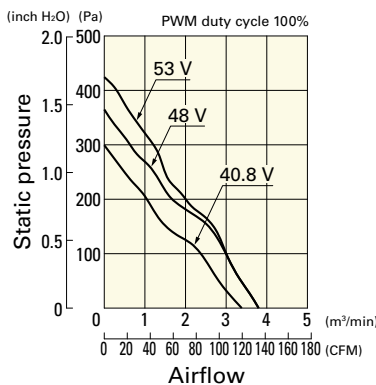

PWM duty - Speed characteristics example

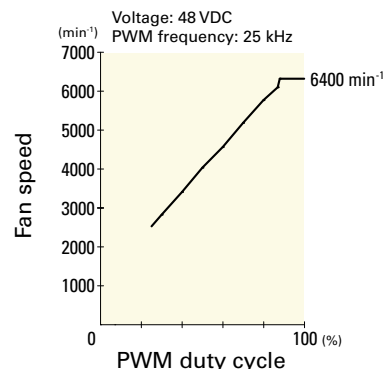

9GA1248P4S001 With pulse sensor with PWM control function

PWM duty cycle

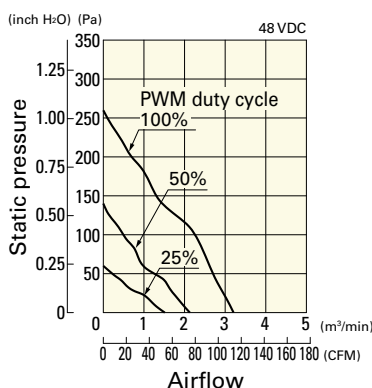

Operating voltage range

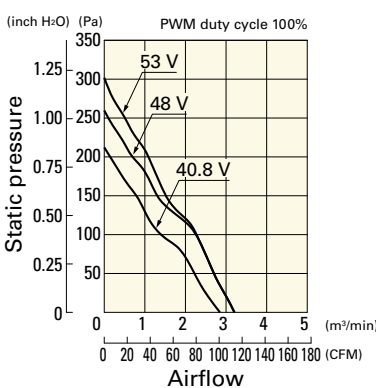

PWM duty - Speed characteristics example

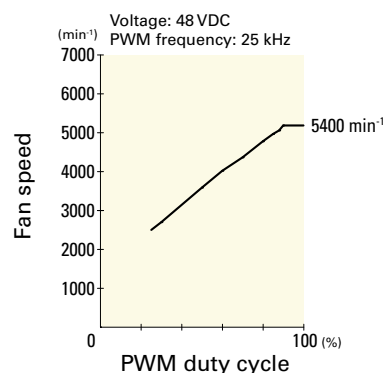

Airflow - Static Pressure Characteristics

9GA1212G4001 With pulse sensor

Operating voltage range

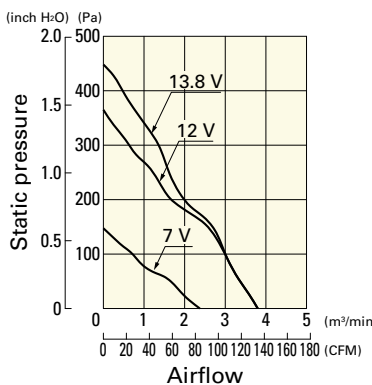

9GA1212S4001 With pulse sensor

Operating voltage range

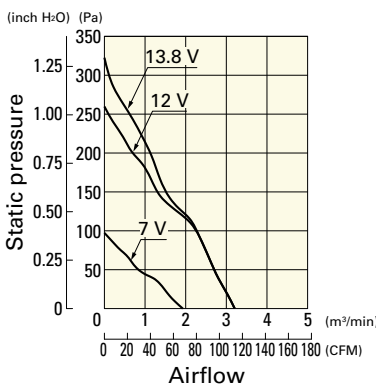

9GA1224G4001 With pulse sensor

Operating voltage range

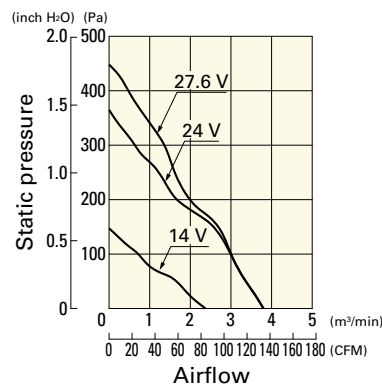

Airflow - Static Pressure Characteristics

9GA1224S4001 With pulse sensor

Operating voltage range

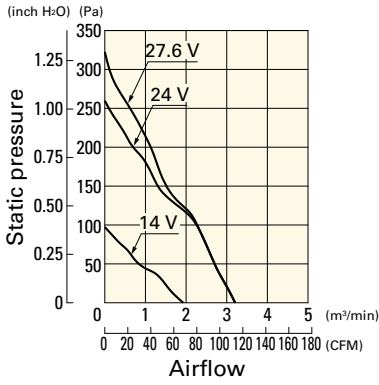

9GA1248G4001 With pulse sensor

Operating voltage range

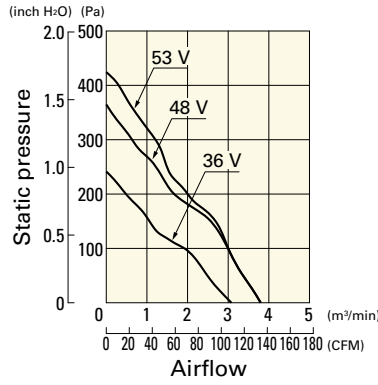

9GA1248S4001 With pulse sensor

Operating voltage range

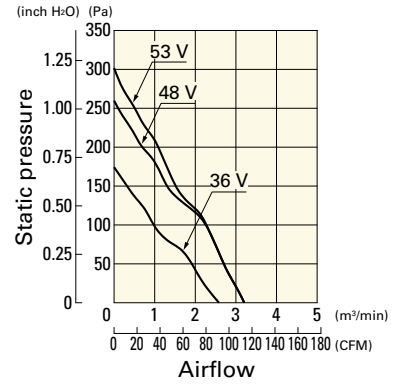

Dimensions (unit: mm) (With pulse sensor with PWM control function)

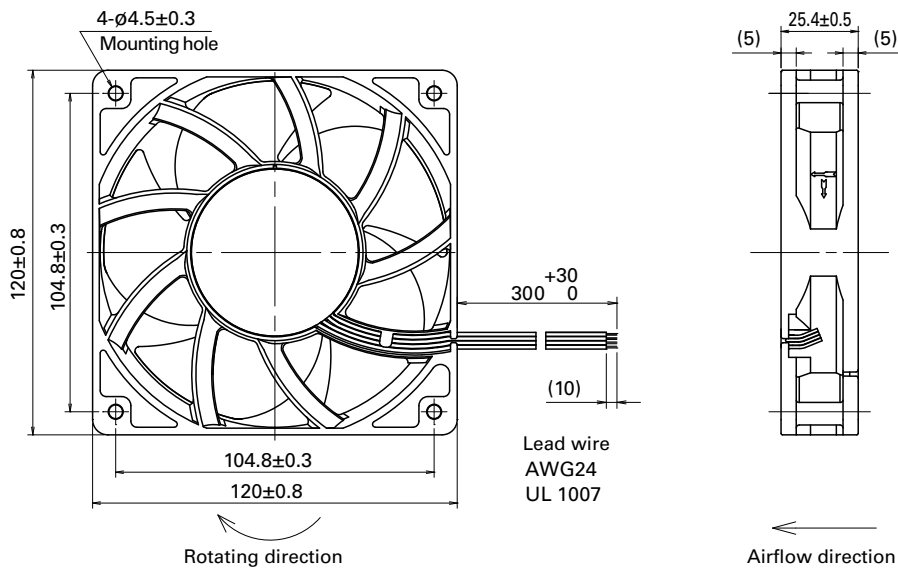

Reference Dimensions of Mounting Holes and Vent Opening (unit: mm)

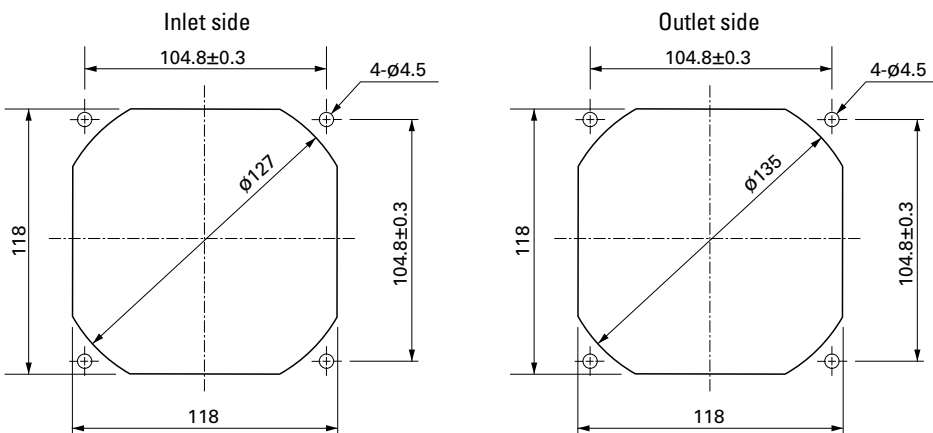

Options

Finger guards

page: p. 559

Model no.: 109-019E, 109-019K, 109-019C, 109-019H

Resin finger guards

page: p. 565

Model no.: 109-1000G

Resin filter kits

page: p. 566

Model no.: 109-1000F13 (13PPI), 109-1000F20 (20PPI),
109-1000F30 (30PPI), 109-1000F40 (40PPI)



120x120x25 mm

San Ace 120 9GV type US

General Specifications

- Material Frame: Plastic (Flammability: UL 94V-0), Impeller: Plastic (Flammability: UL 94V-1)
- Expected life See the table below. (L10 life: 90% survival rate for continuous operation in free air at 60°C, rated voltage) Expected life at 40°C is for reference only.
- Motor protection function Locked rotor burnout protection, Reverse polarity protection
For details, please refer to p. 573.
- Dielectric strength 50/60 Hz, 500 VAC, for 1 minute (between lead wire conductors and frame)
- Insulation resistance 10 MΩ or more with a 500 VDC megger (between lead wire conductors and frame)
- Sound pressure level (SPL) At 1 m away from the air inlet
- Storage temperature -30 to +70°C (Non-condensing)
- Lead wire ⊕Red ⊖Black Sensor Yellow Control Brown
- Mass 260 g

Specifications

The models listed below **have ribs and pulse sensors with PWM control function.** For models without ribs, append "1" to the end of model numbers.

| Model no. | Rated voltage [V] | Operating voltage range [V] | PWM duty cycle* [%] | Rated current [A] | Rated input [W] | Rated speed [min ⁻¹] | Max. airflow [m ³ /min] [CFM] | Max. static pressure [Pa] [inchH ₂ O] | SPL [dB (A)] | Operating temperature [°C] | Expected life [h] |
|--------------|-------------------|-----------------------------|---------------------|-------------------|-----------------|----------------------------------|--|--|--------------|----------------------------|-------------------------|
| 9GV1212P4G01 | 12 | 10.2 to 13.8 | 100 | 1.68 | 20.16 | 5100 | 4.83 171 | 224 0.9 | 58 | -20 to +70 | 40000/60°C (70000/40°C) |
| | | | 0 | 0.18 | 2.16 | 1650 | 1.56 55.1 | 23.5 0.09 | 30 | | |
| 9GV1224P4G01 | 24 | 20.4 to 27.6 | 100 | 0.84 | 20.16 | 5100 | 4.83 171 | 224 0.9 | 58 | | |
| | | | 0 | 0.13 | 3.12 | 1650 | 1.56 55.1 | 23.5 0.09 | 30 | | |
| 9GV1248P4J01 | 48 | 40.8 to 55.2 | 100 | 0.5 | 24.0 | 5400 | 5.11 180 | 251 1.01 | 59 | | |
| | | | 0 | 0.15 | 7.2 | 3000 | 2.84 100 | 77.5 0.31 | 47 | | |
| 9GV1248P4G01 | 48 | 40.8 to 60.0 | 100 | 0.42 | 20.16 | 5100 | 4.83 171 | 224 0.9 | 58 | | |
| | | | 0 | 0.07 | 3.36 | 1650 | 1.56 55.1 | 23.5 0.09 | 30 | | |
| 9GV1248P4H01 | 48 | 40.8 to 60.0 | 100 | 0.33 | 15.84 | 4600 | 4.35 154 | 182 0.73 | 55 | | |
| | | | 0 | 0.07 | 3.36 | 1650 | 1.56 55.1 | 23.5 0.09 | 30 | | |

* PWM input frequency is 25 kHz; models without specifications at 0% PWM duty cycle have zero fan speed at 0%.

The following sensor and control options are available for selection.

Differs according to the model. Refer to the table on p. 607. Without sensor Pulse sensor Lock sensor

Airflow - Static Pressure Characteristics / PWM Duty - Speed Characteristics Example

9GV1212P4G01 With pulse sensor with PWM control function

PWM duty cycle

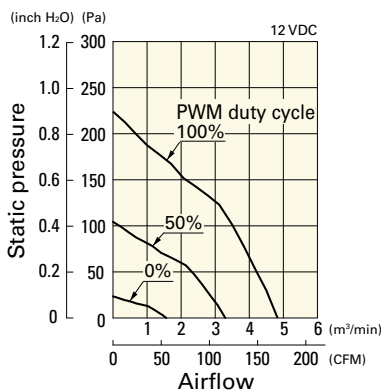

Operating voltage range

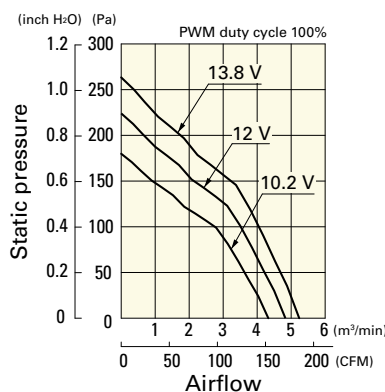

PWM duty - Speed characteristics example

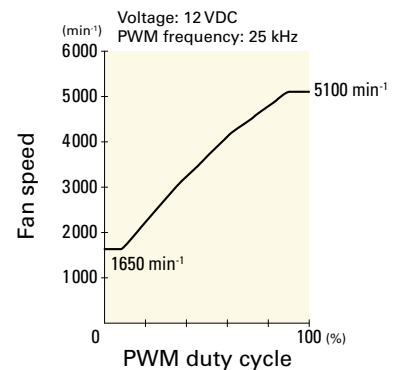

Airflow - Static Pressure Characteristics / PWM Duty - Speed Characteristics Example

9GV1224P4G01 With pulse sensor with PWM control function

PWM duty cycle

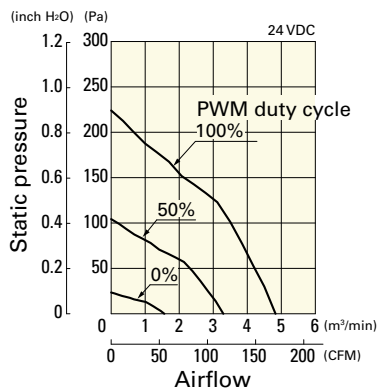

Operating voltage range

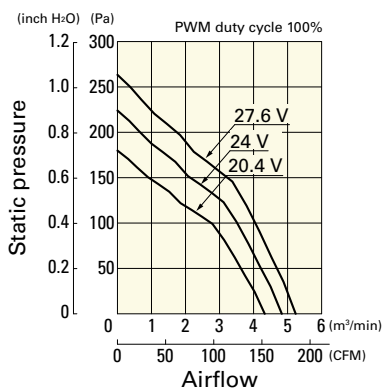

PWM duty - Speed characteristics example

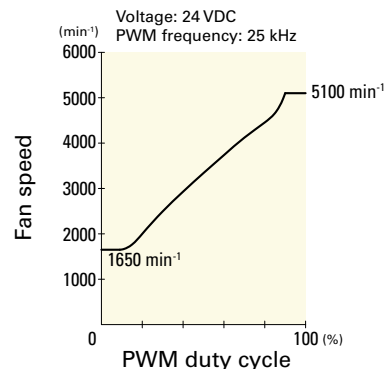

9GV1248P4J01 With pulse sensor with PWM control function

PWM duty cycle

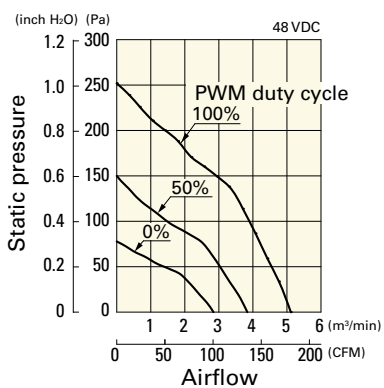

Operating voltage range

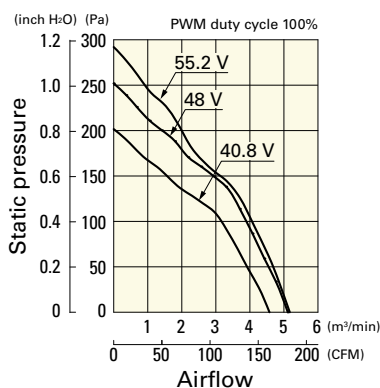

PWM duty - Speed characteristics example

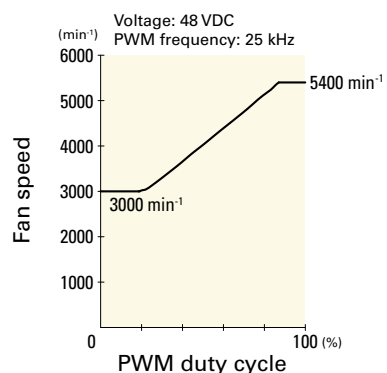

9GV1248P4G01 With pulse sensor with PWM control function

PWM duty cycle

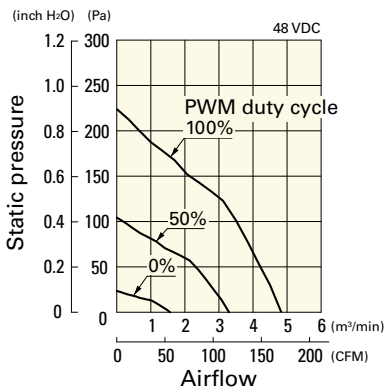

Operating voltage range

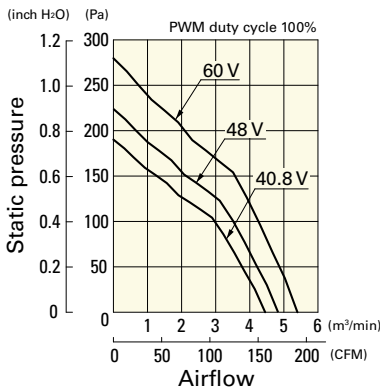

PWM duty - Speed characteristics example

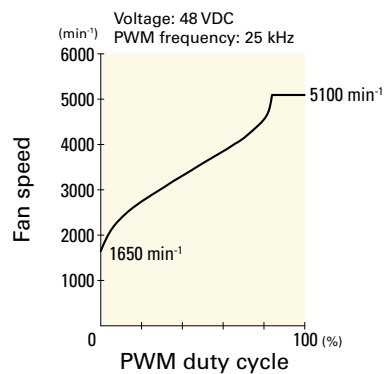

9GV1248P4H01 With pulse sensor with PWM control function

PWM duty cycle

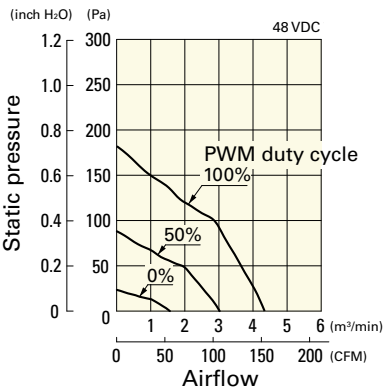

Operating voltage range

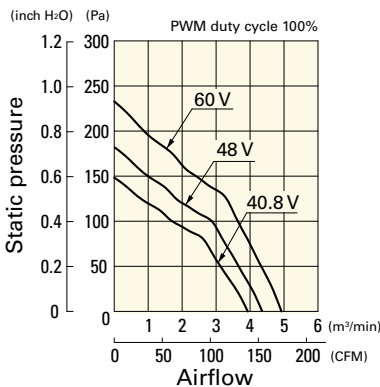

PWM duty - Speed characteristics example

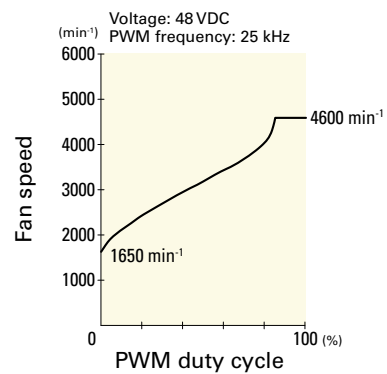

Dimensions (unit: mm) (With ribs)

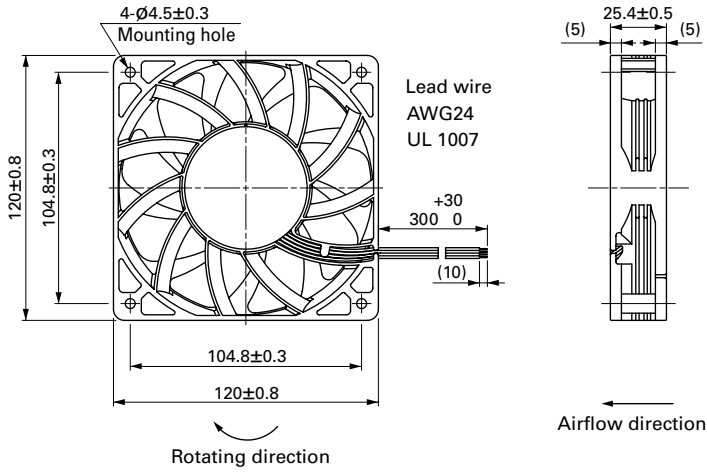

Reference Dimensions of Mounting Holes and Vent Opening (unit: mm)

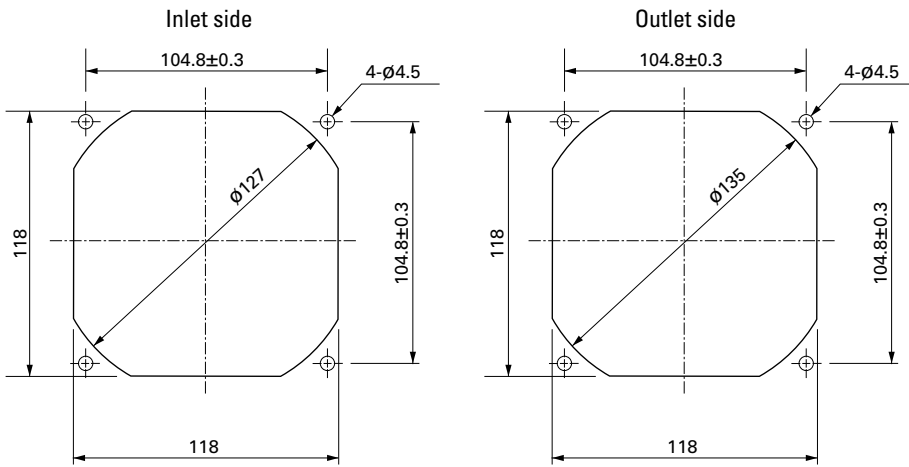

Options

Finger guards

page: p. 559

Model no.: 109-019E, 109-019K, 109-019C, 109-019H

Resin finger guards

page: p. 565

Model no.: 109-1000G

Resin filter kits

page: p. 566

Model no.: 109-1000F13 (13PPI), 109-1000F20 (20PPI),
109-1000F30 (30PPI), 109-1000F40 (40PPI)

DC Fan



120x120x25 mm

San Ace 120 9G type Model 9G1212B401 is not certified.

General Specifications

- Material Frame: Plastic (Flammability: UL 94V-0), Impeller: Plastic (Flammability: UL 94V-1)
- Expected life See the table below. (L10 life: 90% survival rate for continuous operation in free air at 60°C, rated voltage)
Expected life at 40°C is for reference only.
- Motor protection function Locked rotor burnout protection, Reverse polarity protection
For details, please refer to p. 573.
- Dielectric strength 50/60 Hz, 500 VAC, for 1 minute (between lead wire conductors and frame)
- Insulation resistance 10 MΩ or more with a 500 VDC megger (between lead wire conductors and frame)
- Sound pressure level (SPL) At 1 m away from the air inlet
- Storage temperature -30 to +70°C (Non-condensing)
- Lead wire ⊕Red ⊖Black or Blue Sensor Yellow
- Mass 240 g

Specifications

The models listed below **have ribs and pulse sensors**. For models without ribs, append "1" to the end of model numbers.

| Model no. | Rated voltage [V] | Operating voltage range [V] | Rated current [A] | Rated input [W] | Rated speed [min ⁻¹] | Max. airflow [m ³ /min] [CFM] | Max. static pressure [Pa] [inchH ₂ O] | SPL [dB (A)] | Operating temperature [°C] | Expected life [h] | |
|--------------|-------------------|-----------------------------|-------------------|-----------------|----------------------------------|--|--|--------------|----------------------------|----------------------------|----|
| » 9G1212G401 | 12 | 10.2 to 13.8 | 0.9 | 10.8 | 4100 | 3.68 130 | 120 0.482 | 51 | -20 to +70 | 40000/60°C (70000/40°C) | |
| » 9G1212E401 | | | 0.58 | 6.96 | 3650 | 3.25 115 | 98 0.394 | 48 | | | |
| » 9G1212A401 | | | 0.4 | 4.8 | 3150 | 2.83 100 | 77 0.309 | 44 | | | |
| » 9G1212H401 | | 6 to 13.8 | 0.31 | 3.72 | 2850 | 2.5 88 | 64 0.257 | 40 | | | |
| » 9G1212F401 | | 7 to 13.8 | 0.19 | 2.28 | 2250 | 1.98 70 | 42 0.169 | 35 | | | |
| » 9G1212M401 | | | 0.14 | 1.68 | 1950 | 1.66 59 | 31 0.124 | 29 | | | |
| » 9G1212B401 | | 10.2 to 13.8 | 0.06 | 0.72 | 1000 | 0.88 31 | 9.6 0.039 | 18 | | | |
| » 9G1224G401 | | 24 | 20.4 to 27.6 | 0.47 | 11.28 | 4100 | 3.68 130 | 120 0.482 | | | 51 |
| » 9G1224E401 | | | | 0.37 | 8.88 | 3650 | 3.25 115 | 98 0.394 | | | 48 |
| » 9G1224A401 | | | | 0.21 | 5.04 | 3150 | 2.83 100 | 77 0.309 | | | 44 |
| » 9G1224H401 | 12 to 27.6 | | 0.17 | 4.08 | 2850 | 2.5 88 | 64 0.257 | 40 | | | |
| » 9G1224F401 | 20.4 to 27.6 | | 0.1 | 2.4 | 2250 | 1.98 70 | 42 0.169 | 35 | | | |
| » 9G1224M401 | | | 0.08 | 1.92 | 1950 | 1.66 59 | 31 0.124 | 29 | | | |
| » 9G1248G401 | 48 | | 40.8 to 55.2 | 0.23 | 11.04 | 4100 | 3.68 130 | 120 0.482 | 51 | | |
| » 9G1248E401 | | | | 0.16 | 7.68 | 3650 | 3.25 115 | 98 0.394 | 48 | | |
| » 9G1248A401 | | | | 0.13 | 6.24 | 3150 | 2.83 100 | 77 0.309 | 44 | | |
| » 9G1248H401 | | | | 0.1 | 4.8 | 2850 | 2.5 88 | 64 0.257 | 40 | | |
| » 9G1248F401 | | 0.06 | | 2.88 | 2250 | 1.98 70 | 42 0.169 | 35 | | | |
| » 9G1248M401 | | 0.05 | | 2.4 | 1950 | 1.66 59 | 31 0.124 | 29 | | | |

The following sensor and control options are available for selection.

Differs according to the model. Refer to the table on pp. 601 to 602. Without sensor Lock sensor PWM control

The » mark indicates Short LeadTime Service applicable models. See p. 626 for details.

Airflow - Static Pressure Characteristics

9G1212G401 With pulse sensor

Operating voltage range

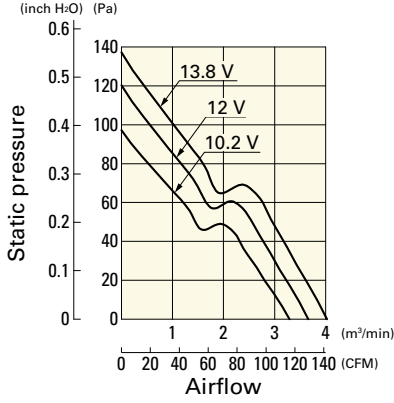

9G1212E401 With pulse sensor

Operating voltage range

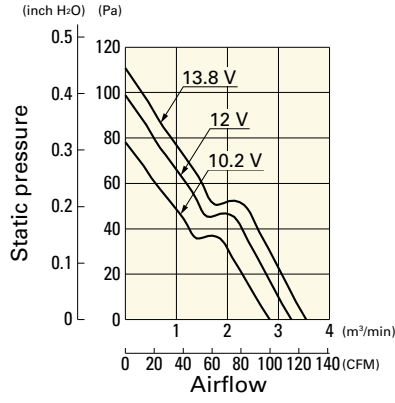

9G1212A401 With pulse sensor

Operating voltage range

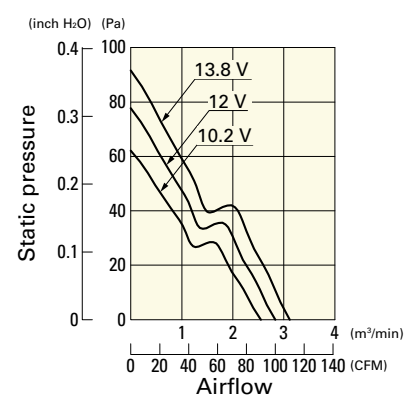

9G1212H401 With pulse sensor

Operating voltage range

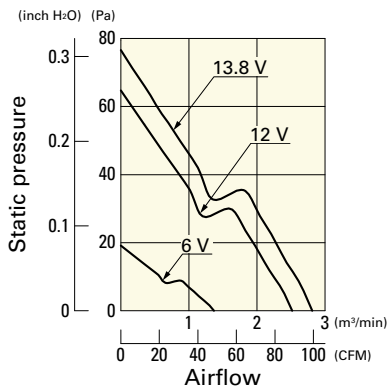

9G1212F401 With pulse sensor

Operating voltage range

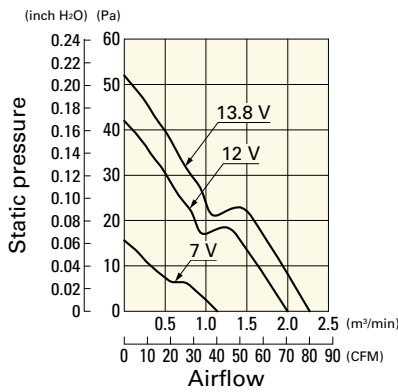

9G1212M401 With pulse sensor

Operating voltage range

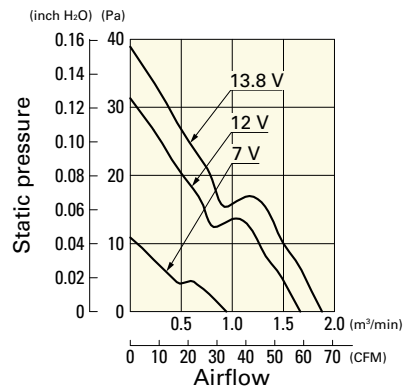

9G1212B401 With pulse sensor

Operating voltage range

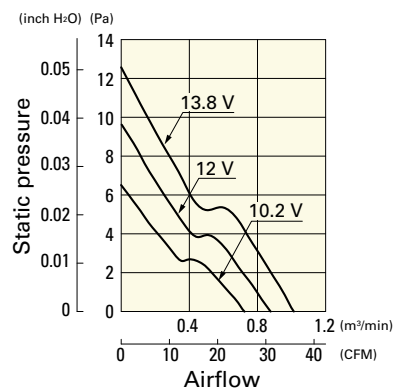

9G1224G401 With pulse sensor

Operating voltage range

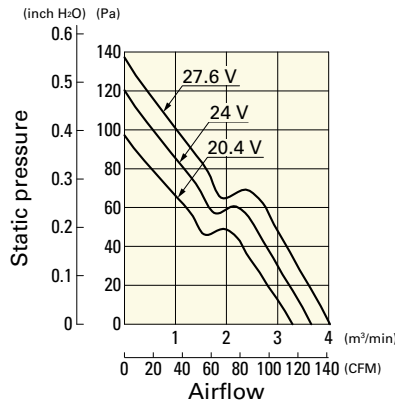

9G1224E401 With pulse sensor

Operating voltage range

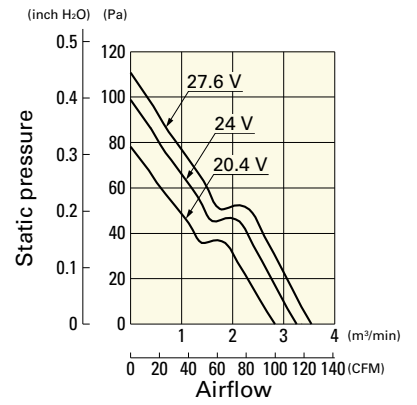

9G1224A401 With pulse sensor

Operating voltage range

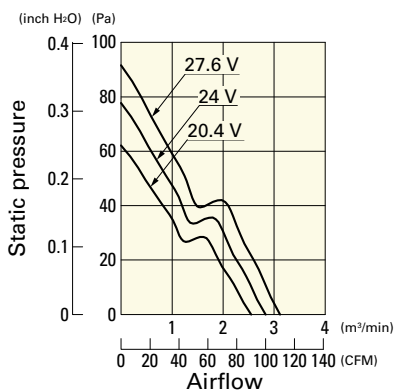

9G1224H401 With pulse sensor

Operating voltage range

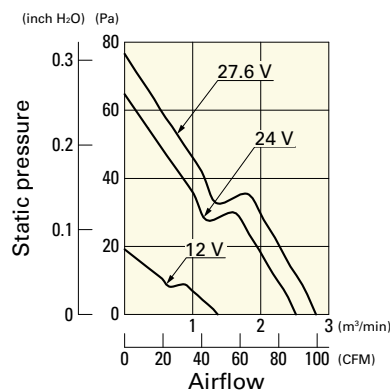

9G1224F401 With pulse sensor

Operating voltage range

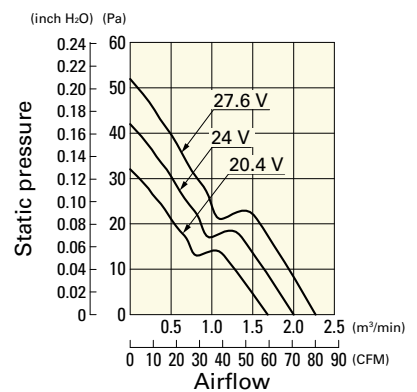

Airflow - Static Pressure Characteristics

9G1224M401 With pulse sensor

Operating voltage range

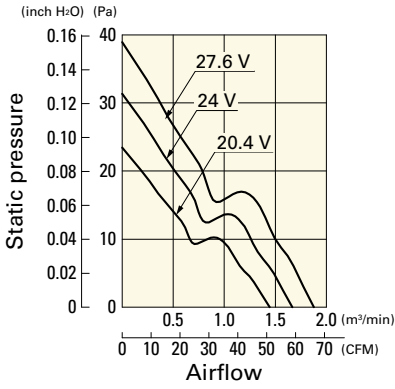

9G1248G401 With pulse sensor

Operating voltage range

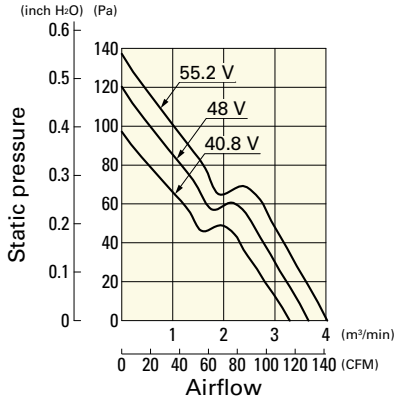

9G1248E401 With pulse sensor

Operating voltage range

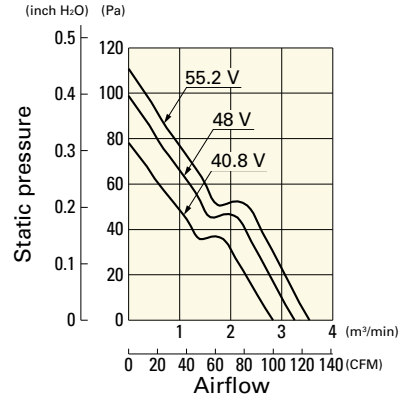

9G1248A401 With pulse sensor

Operating voltage range

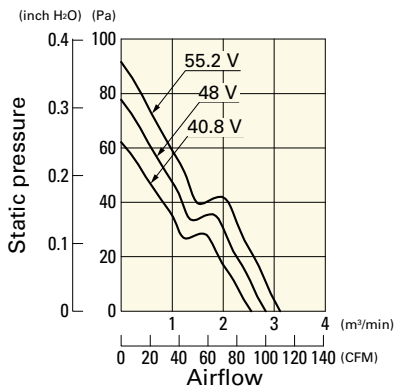

9G1248H401 With pulse sensor

Operating voltage range

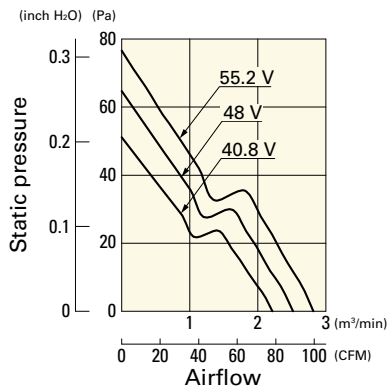

9G1248F401 With pulse sensor

Operating voltage range

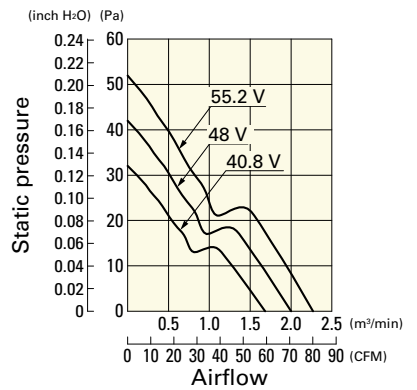

9G1248M401 With pulse sensor

Operating voltage range

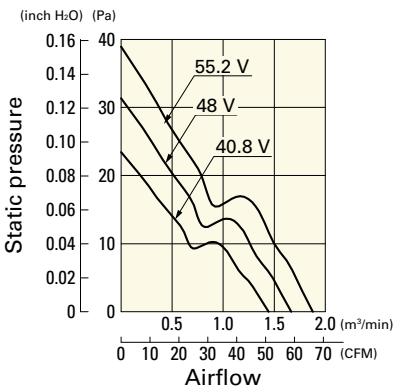

Dimensions (unit: mm) (With ribs)

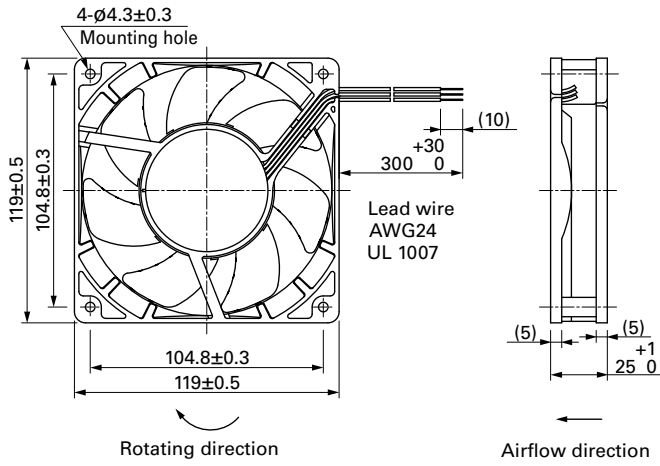

Reference Dimensions of Mounting Holes and Vent Opening (unit: mm)

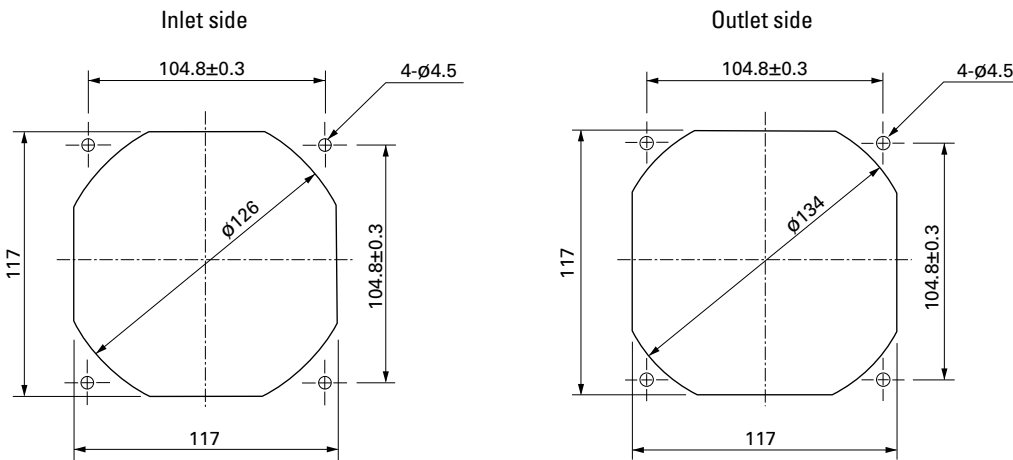

Options

Finger guards

page: p. 559

Model no.: 109-019E, 109-019K, 109-019C, 109-019H

Resin finger guards

page: p. 565

Model no.: 109-1000G

Resin filter kits

page: p. 566

Model no.: 109-1000F13 (13PPI), 109-1000F20 (20PPI),
109-1000F30 (30PPI), 109-1000F40 (40PPI)

DC Fan

120×120×25 mm



San Ace 120 9S type Silent Fan **US**

General Specifications

- Material Frame: Plastic (Flammability: UL 94V-0), Impeller: Plastic (Flammability: UL 94V-1)
- Expected life See the table below. (L10 life: 90% survival rate for continuous operation in free air at 60°C, rated voltage)
Expected life at 40°C is for reference only.
- Motor protection function Locked rotor burnout protection, Reverse polarity protection
For details, please refer to p. 573.
- Dielectric strength 50/60 Hz, 500 VAC, for 1 minute (between lead wire conductors and frame)
- Insulation resistance 10 MΩ or more with a 500 VDC megger (between lead wire conductors and frame)
- Sound pressure level (SPL) At 1 m away from the air inlet
- Storage temperature -30 to +70°C (Non-condensing)
- Lead wire ⊕Red ⊖Black Sensor Yellow
- Mass 140 g

Specifications

The models listed below **have ribs and pulse sensors**. For models without ribs, append "1" to the end of model numbers.

| Model no. | Rated voltage [V] | Operating voltage range [V] | Rated current [A] | Rated input [W] | Rated speed [min ⁻¹] | Max. airflow [m ³ /min] [CFM] | Max. static pressure [Pa] [inchH ₂ O] | SPL [dB (A)] | Operating temperature [°C] | Expected life [h] |
|--------------|-------------------|-----------------------------|-------------------|-----------------|----------------------------------|--|--|--------------|----------------------------|----------------------------|
| » 9S1212H401 | 12 | 5.0 to 13.2 | 0.39 | 4.68 | 2700 | 2.45 86.5 | 45.2 0.18 | 36 | -10 to +60 | 40000/60°C (70000/40°C) |
| » 9S1212F401 | | 5.0 to 13.8 | 0.19 | 2.28 | 2200 | 2.0 70.6 | 30.0 0.12 | 30 | | |
| » 9S1212M401 | | 6.0 to 13.8 | 0.13 | 1.56 | 1850 | 1.66 58.6 | 22.7 0.09 | 24 | | |
| » 9S1212L401 | | 7.0 to 13.8 | 0.08 | 0.96 | 1500 | 1.36 48.1 | 14.9 0.06 | 17 | | |
| » 9S1224M401 | | 24 | 14 to 26.4 | 0.06 | 1.44 | 1850 | 1.66 58.6 | 22.7 0.09 | | |

The following sensor and control options are available for selection.

Available for all models. **Without sensor**

Differs according to the model. Refer to the table on p. 610. **Lock sensor** **PWM control**

The » mark indicates Short Lead Time Service applicable models. See p. 626 for details.

Airflow - Static Pressure Characteristics

9S1212H401 With pulse sensor

Operating voltage range

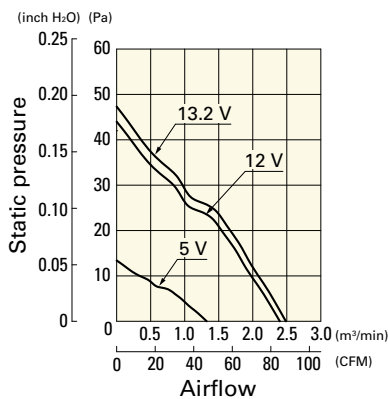

9S1212F401 With pulse sensor

Operating voltage range

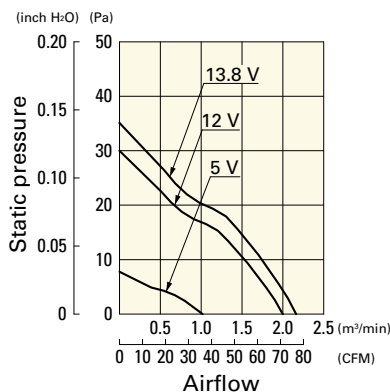

9S1212M401 With pulse sensor

Operating voltage range

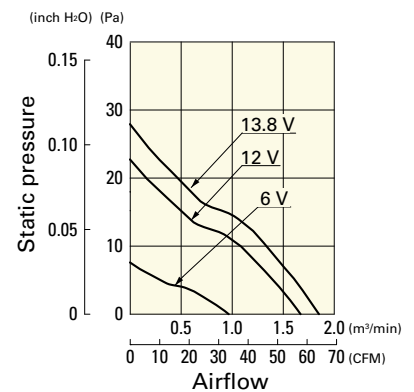

Airflow - Static Pressure Characteristics

9S1212L401 With pulse sensor

Operating voltage range

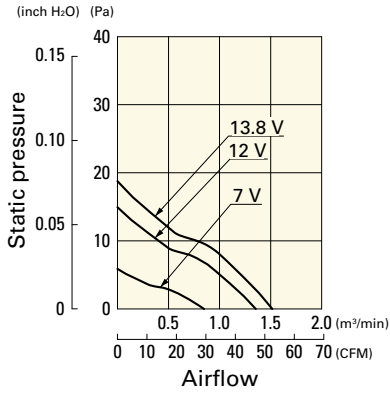

9S1224M401 With pulse sensor

Operating voltage range

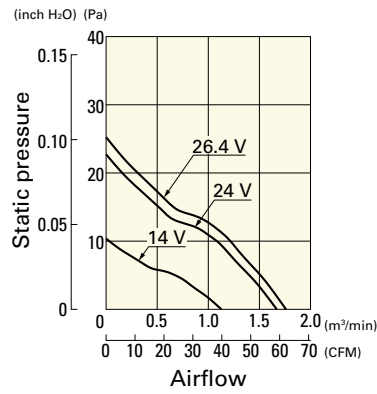

Dimensions (unit: mm) (With ribs)

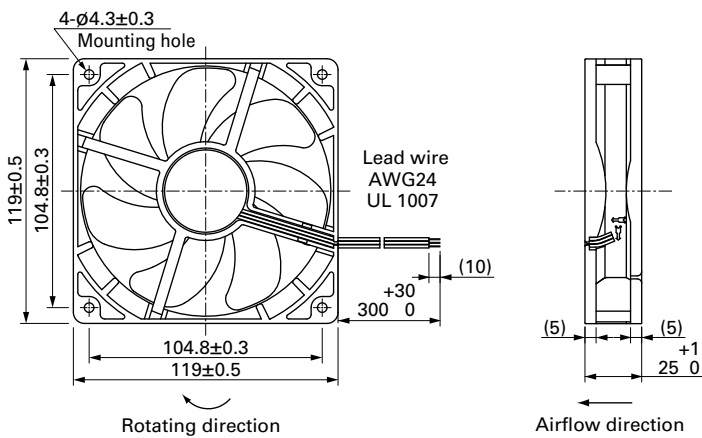

Reference Dimensions of Mounting Holes and Vent Opening (unit: mm)

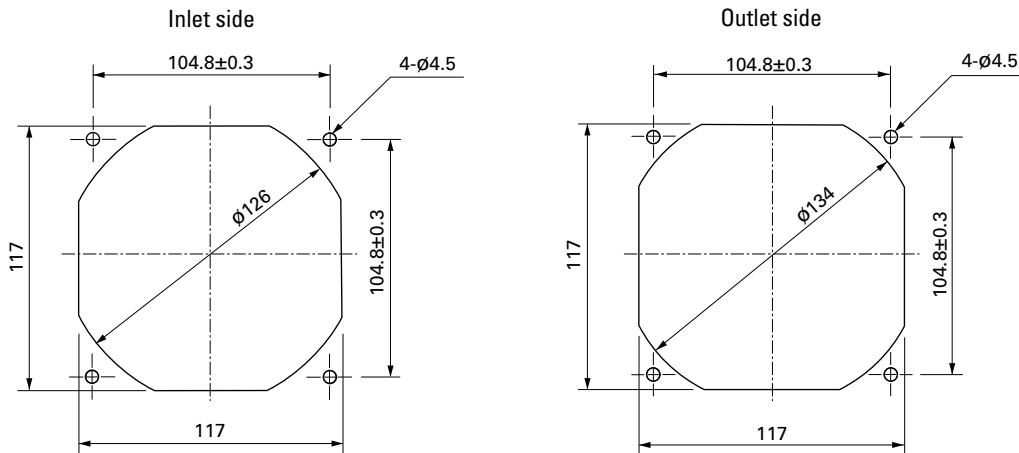

Options

Finger guards

page: p. 559

Model no.: 109-019E, 109-019K, 109-019C, 109-019H

Resin finger guards

page: p. 565

Model no.: 109-1000G

Resin filter kits

page: p. 566

Model no.: 109-1000F13 (13PPI), 109-1000F20 (20PPI),
109-1000F30 (30PPI), 109-1000F40 (40PPI)